

**CUSTOMIZED PRODUCT PRICING SUMMARY BASED ON CONTRACT**

Cars and Light Trucks

Team Members -- Kevin Moore - Shauna Hood - Jorge Guerra - Alan Rosner

**Contract Name: State of Texas 070 or 072 A1 Texas Smartbuy Contract 2018/2019 Fiscal Year**

End User: City of North Richland Hills Sam Pack's Rep: Alan Rosner  
 Contact: Ed Wright Date: 3/7/2019  
 Contact TN/Email ewright@nrhtx.com Phone # 817-427-7252

Product Description: 2019 Ford E-Series Cutaway with body Exterior Color / Interior White  
 A. Bid Series: 884E Base Price: **\$ 24,300.00**

**B. Published Options (Itemize Each Below)**

Code	Description	Bid Price	Code	Description	Bid Price
	Automatic	Included			
	Power Steering/Brakes	Included			
	Air Conditioning	Included			
	Bluetooth	Included			
	Power Group	Included			
	Speed Control	Included			

Total of B. - Published Options **\$ -**

**C. Factory Published Options**

Code	Description	Bid Price	Code	Description	Bid Price

Total of C. - Dealer Published Options **\$ -**

**D. Options requiring separate PO**

Code	Description	Bid Price	Code	Description	Bid Price
999	Upgrade chassis specs to customer minimums	\$3,070.00			
	Custom body - as per the Armored Group	\$52,516.00			

Total of D. - Off Menu Options **\$ 55,586.00**

F.	Delivery Charges	0 Miles @ \$2.45/mile	\$ -
G.	Option Discounts		\$ -
H.	Total of A + B + C + D + E = F		\$ 79,886.00
I.	Floor Plan Assistance		\$0.00
J.	Lot Insurance Coverages		\$0.00
K.	Quantity Ordered <u>1</u> X F =		\$ 79,886.00
L.	Administrative Fee		\$ -
M.	Non-Equip Charges & Credits		
N.	<b>TOTAL PURCHASE PRICE INCLUDING ADMIN FEE</b>		<b>\$79,886.00</b>

## Chassis Specifications

**Year, Make, & Model:** 2019 E-450 Cutaway **GVWR:** 14,500  
**Wheelbase:** 176" **CA:** 118" **Frame Width:** 42" **Engine:** Gas  
**VIN#:**  Drop Ship Chassis  Bought Chassis  
**Chassis ETA:** **Dealer Name:** Five Star Ford Carrollton

## General Specifications

**Base Body:** RDV 16' long 78" high 96" wide  
**Floor:** Wheelwells - 1-1/2" x 3" tube crossmembers, Puck mounted, 1-1/8" laminated hardwood with Spray on Non-Skid liner. Precoated understructure.  
**Front Wall:** 1/2" White FRP with 4" setback solid bulkhead with a horizontal 12" x 18" Slider Window. Reinforce for custom Vest Rod installation as needed.  
**Sidewalls:** 1/2" White FRP to extend down as skirt.  
**Rear Frame:** 12ga. Galvannealed Steel Corner Posts, Header and One Piece 10ga Steel Threshold. 1/2" FRP Rear Wall framed for double narrow 48" rear doors  
**Attic:** 3ft Attic with a 3" lip for cargo control.  
**Roof:** .032 one-piece aluminum bonded to galvanized steel roof bows on 16" centers - 3/8" plywood on ceiling with .090 Glassboard Liner full roof.  
**Corners:** 2" Extruded Aluminum vertical front corner posts.  
**Wind Deflector:** Square Front. No Wind Deflector.  
**Exterior Lights:** LED FMVSS 108 Clearance lights  
**S/T/T Lights:** LED oval taillights with integrated back-up lights surface mounted  
**Mounting:** Mounted at The Armored Group, Dearborn Heights MI with standard mudflaps

## Options

**Bumper:** 12" deep Grip Strut rear step bumper  
**Rear Doors:** Challenger 1550 series double narrow 48" doors with D Ring Locking handle, Hansen hardware, shock assist to hold C/S door at 95 degrees, 4" Aluminum T Style holdback on S/S door and (2) Grab handles.  
**Compartments:** 14' of Body Compartments on both sides starting at front wall. Each side will have a total of 4 compartments 2 vertical compartments then a horizontal compartment and then 1 vertical compartment. There should be approx. 24" between rear compartments and back wall. Each vertical compartment to have (2) adjustable and removable shelves and shock assist to hold doors at 110 degrees. C/S Horizontal compartment will have 2 slide out trays with 100lbs capacity and 8 dividers each. S/S Horizontal Compartment will have a Slide Master SM2, that will extend into body, to hold Aux Batteries, Invertor & Body Electrical Panel. This Compartment will **not** have an exterior door but a Louvered Interior Access Panel. Compartment Doors will be Challenger 1550 Doors with lockable D Ring Latches and LED Light Strips with pin switches in door frames for activation. Horizontal door to have removable cables. Key all doors alike. Master Lock style rod on both sides with latches at front wall.  
**Cargo Control:** Install (116) surface mount D Rings. 12 in each Vertical compartment in groups of 2 on front and rear walls of compartment at 10", 20" and 30" up from floor of compartment and 22 on each side wall 18" apart from front wall to rear wall 10" up from top of compartments and 10" below ceiling.  
**Vest Rails:** On both sides of body fabricate a 8ft long Vest Rail capable of holding 600 lbs for ballistic vests that use special customer provided hangers. Locate between Front Wall and Fixed Shelves.

- Interior Lights:** Install (5) 72" KII 12 volt LED light bars, 1 in attic and 4 spaced evenly on ceiling of vehicle with switch located at rear wall hotwired thru a Polytron DL-10 60 minute or equivalent timer.
- Shelves:** Install 22.5" deep fixed shelves. On S/S 1 shelf approx. 6ft from Vest Rod to end of Compartments 20" above compartments. On C/S 3 shelves. One approx 8ft from Vest Rod to rear wall 20" up from compartments, second approx. 2ft from end of compartments to Rear Wall at Compartment Height and third approx. 2ft 21" up from floor between compartments and Rear Wall. Fabricate from 2" X 2" X 1/8" aluminum angle with 1/2" FRP insert.
- Emergency Lights:** (8) Whelen ION Duo Red/Blue Lights #TLI2J. 1 installed at each top corner of both sidewalls and Rear Header and 2 in front grill. Powered thru switched ignition. Switch Control in Siren Head.
- Scene Lights:** Install (4) Tecniq K90 Scene Lights-1 at each sidewall upper corner below awning. Controlled by (2) Switches, 1 for each pair on a wall (C/S & S/S ) powered by Aux Batteries. Locate switches on rear wall.
- Siren/PA:** Install 100 watt Siren/PA system with Emergency Light control (Code3 3672L4S & E3100U).
- Invertor:** 3,000 Watt Pure Sine Wave Invertor/Charger UP12/3000PCUL with GFCI Outlet, Built in Transfer Relay, Circuit Breakers & 4 Step Intelligent Battery Charger . Locate on slide out tray in S/S Horizontal Compartment with Aux. Batteries.
- Shore Power:** Install a Kussmaul 120V, 20amp auto eject plug with cord. Install using 10ga wire/cable.
- 120vac Receptacles:** (10) Single gang 120vac receptacles. Install 1 per compartment on the interior up as high as possible on back wall. 1 outlet of invertor thru a junction box will power the S/S receptacles and the other invertor outlet thru a junction box will power the C/S receptacles. Run all cables/wiring and install recepticals in Wire Trough.
- Auxiliary Batteries:** Install (2) Optima Blue Top Deep Cycle AGM (D31M) Auxiliary Batteries in S/S Horizontal Compartment with 200 amp battery seperator (Eaton 1315-200). Use 3/0 cables, 150 amp Cicuit Breaker between OEM Battery and Seperator and 300 amp fuses on Invertor Aux Battery side.
- Wiring Notes:** All exposed cables/wiring in body to have metal covers for protection. Compartments to have Wire Trough running along upper rear wall for wiring and receptical installation.
- Ladder Rack:** (5) Aluminum Cross Bar Ladder Rack
- Rear Ladder:** Aluminum Ladder at Rear for Ladder Rack Access. Install on C/S Rear Wall.
- Awnings:** Install (2) 177 inch Freedom Wall Mount 12 volt powered Awnings with Silver Fade Vinyl Canopy and White Case (CoC 351776D25TM). 1 on each sidewall. Install controls on rear wall.
- Back Up Camera:** Install a Back Up Camera with a 7" color LCD monitor in the cab.

PRELIMINARY  
NON PRODUCTION PRINT  
2/28/19

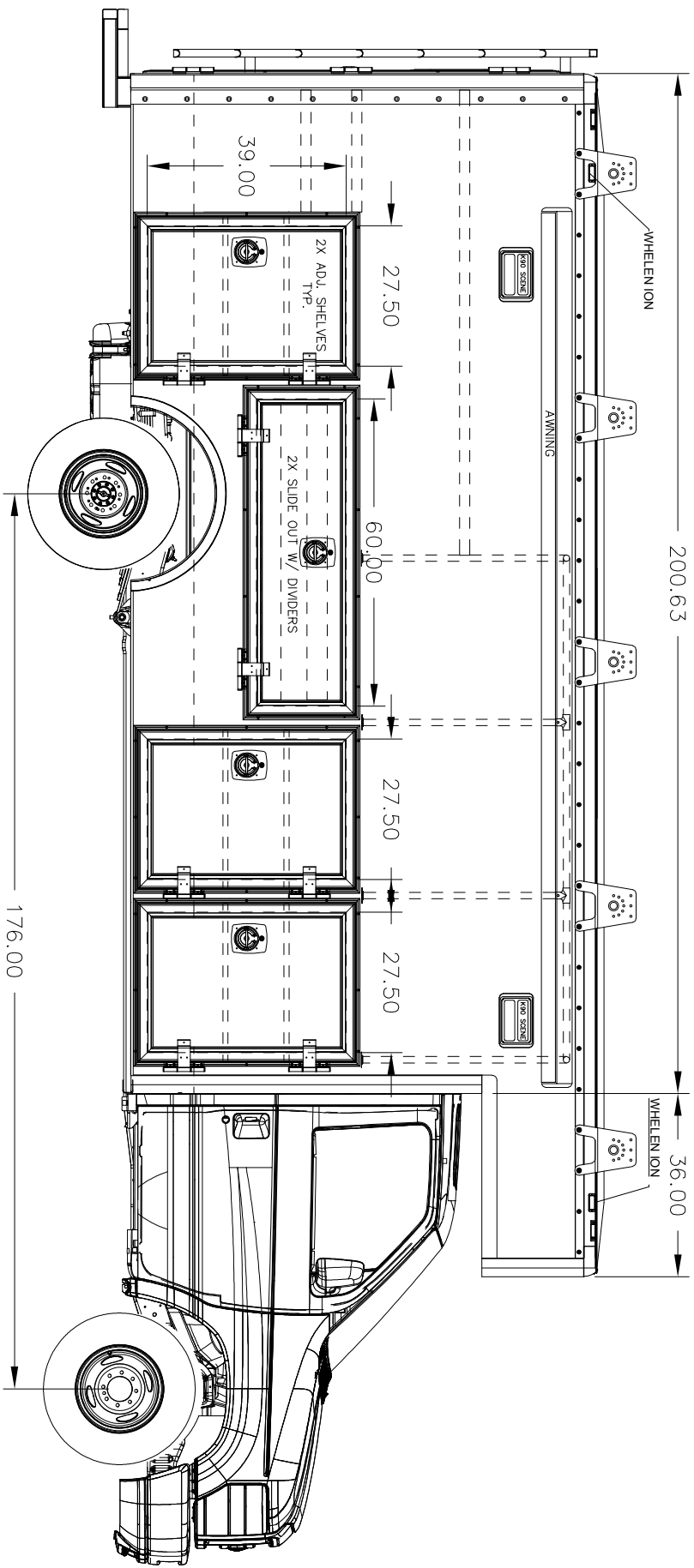

REMOVE ALL BURS AND SHARP EDGES  
\*\*HOLES TO BE FREE AND CLEAR OF WELD SPLATTER

DIMENSIONAL TOLERANCES UNLESS OTHERWISE SPECIFIED	
INCHES	MILLIMETERS
1-PLACE ±.08	1-PLACE ±.2 mm
2-PLACE ±.03	2-PLACE ±.1 mm
3-PLACE ±.01	3-PLACE ±.25 mm
ANGLES ± 1 DEGREES	

**THE ARMORED GROUP**  
2727 S BEECH DALY  
DEARBORN HEIGHTS, MI 48125  
PH (855) TAG-SAFE ~ (855) 824-7233

MATERIAL	TITLE
FINISH	NORTH RICHLAND HILLS PD
PAINT	CURBSIDE
WEIGHT	SCALE
DRW. BY	DATE
DRW. BY	DATE
DRWING NUMBER	REVISED
DESCRIPTION	DATE
DATE	DATE
DATE	DATE

LAST SAVED: 2/6/2019 SHEET 1 OF 1

PRELIMINARY  
NON PRODUCTION PRINT  
2/28/19

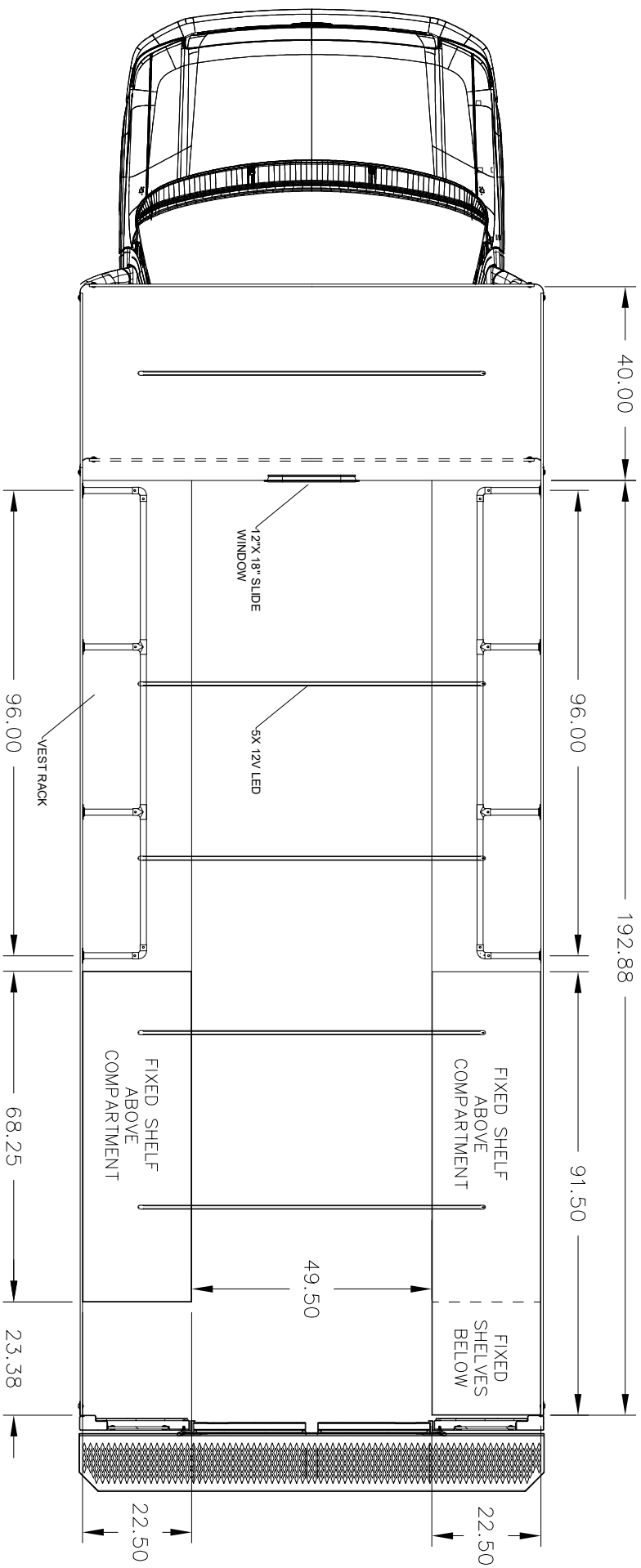

DIMENSIONAL TOLERANCES UNLESS OTHERWISE SPECIFIED

INCHES		MILLIMETERS	
1-PLACE ±.08	1-PLACE ±.2 mm	2-PLACE ±.03	2-PLACE ±.1 mm
3-PLACE ±.01	3-PLACE ±.25 mm		

ANGLES ± 1 DEGREES

**THE ARMORED GROUP**

2727 S BEECH DALEY  
DEARBORN HEIGHTS, MI 48125  
PH (855) TAG-SAFE ~ (855) 824-7233

MATERIAL	TITLE
FINISH	NORTH RICHLAND HILLS PD
PAINT	PLAN VIEW

WEIGHT	SCALE	DWG. BY	DATE	CHK. BY	DATE	DRAWING NUMBER
					2/28/2019	MANE/PD/PV

DESCRIPTION: PLAN VIEW

LAST SAVE/D: 2/28/2019

SHEET 1 OF 1

REMOVE ALL BURS AND SHARP EDGES  
\*\*HOLES TO BE FREE AND CLEAR OF WELD SPLATTER

PRELIMINARY  
 NON PRODUCTION PRINT  
 2/28/19

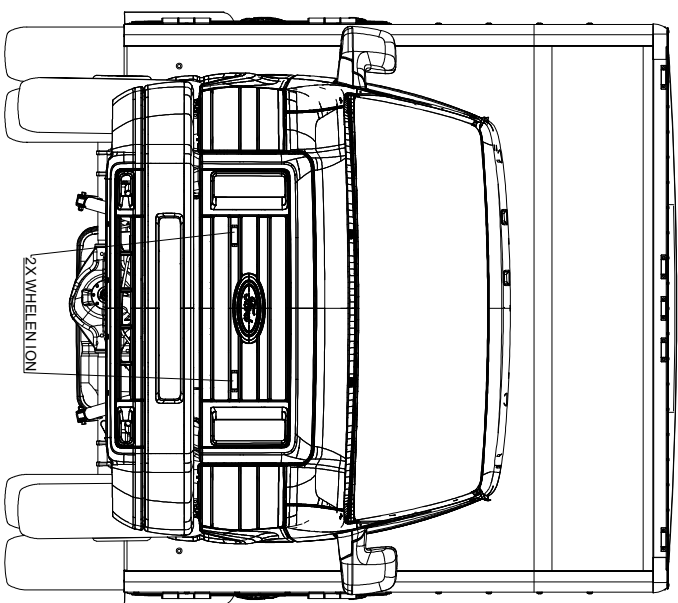
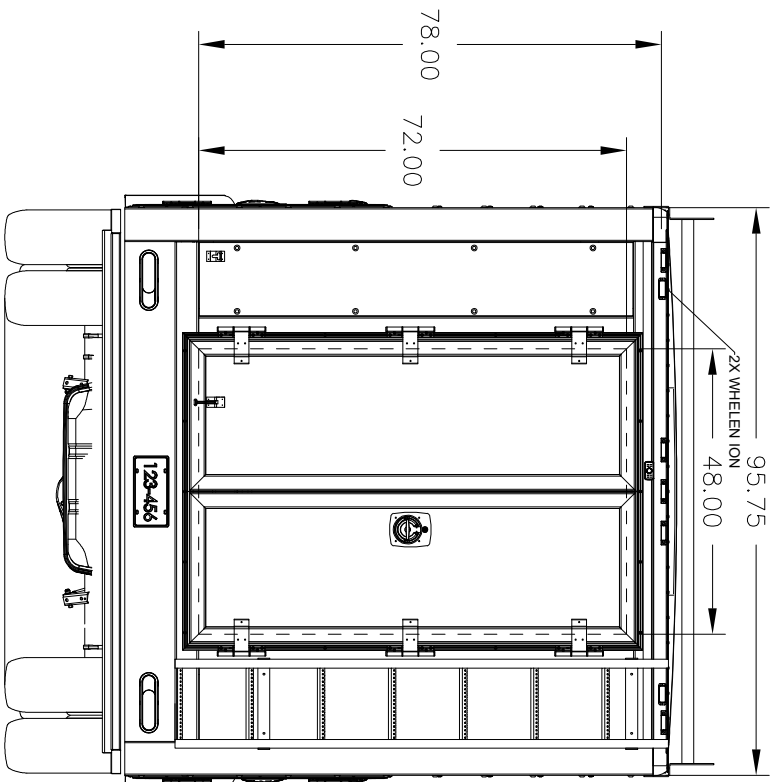

REMOVE ALL BURS AND SHARP EDGES  
 \*\*HOLES TO BE FREE AND CLEAR OF WELD SPLATTER

DIMENSIONAL TOLERANCES UNLESS OTHERWISE SPECIFIED	
INCHES	MILLIMETERS
1-PLACE ±.08	1-PLACE ±.2 mm
2-PLACE ±.03	2-PLACE ±.1 mm
3-PLACE ±.01	3-PLACE ±.25 mm
ANGLES ± 1 DEGREES	

**THE ARMORED GROUP**

2727 S BEECH DALY  
 DEARBORN HEIGHTS, MT 48125  
 PH (855) TAG-SAFE ~ (855) 824-7233

MATERIAL	TITLE	
FINISH	NORTH RICHLAND HILLS PD	
PAINT	PLAN VIEW	
WEIGHT	SCALE	DATE
IN	INL BY	DATE
LAST SAVED: 2/28/2019		DATE
DRAWING NUMBER		DATE
SHEET 1 OF 1		DATE

PRELIMINARY  
NON PRODUCTION PRINT  
2/28/19

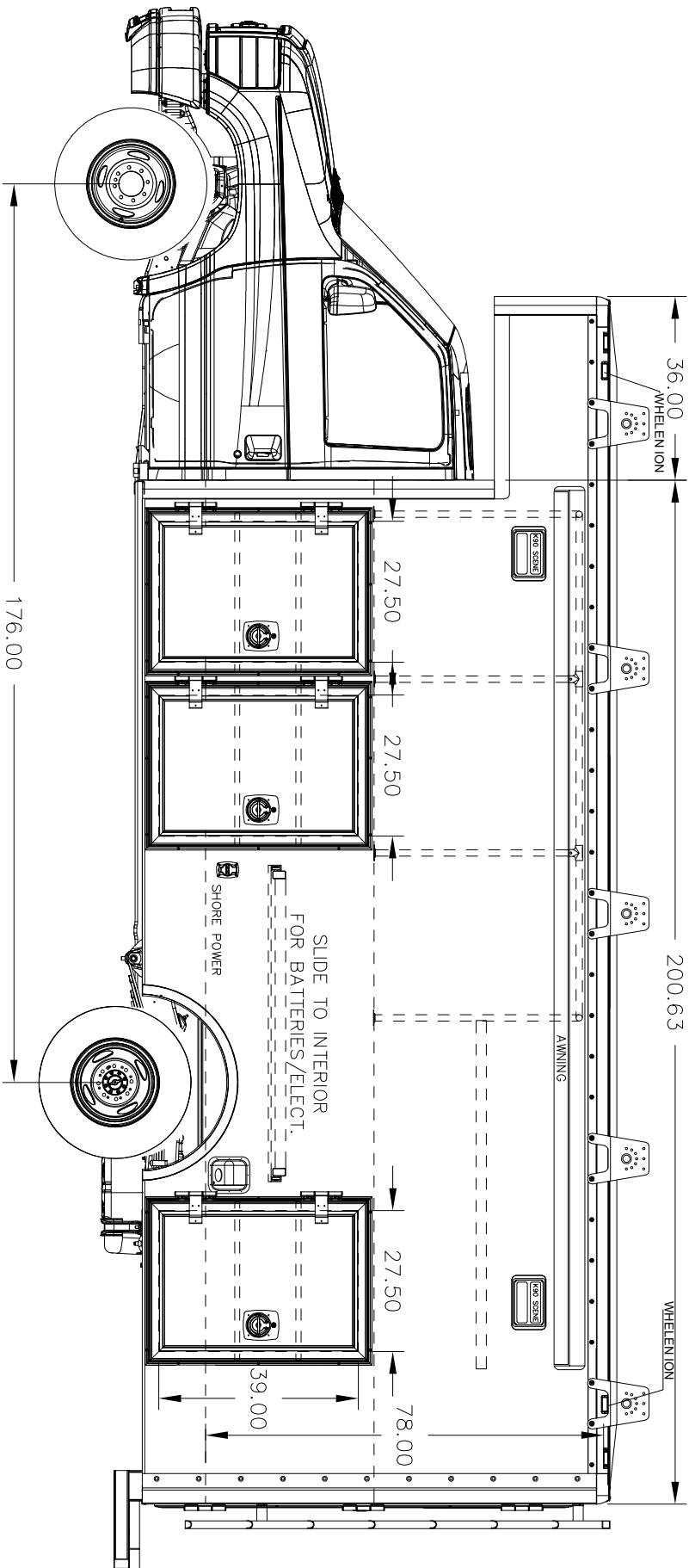

REMOVE ALL BURS AND SHARP EDGES  
\*\*HOLES TO BE FREE AND CLEAR OF WELD SPLATTER

REMOVE ALL BURS AND SHARP EDGES  
\*\*HOLES TO BE FREE AND CLEAR OF WELD SPLATTER

**THE ARMORED GROUP**

2727 S BEECH DALE  
DEARBORN HEIGHTS, MI 48125  
PH (855) TAG-SAFE ~ (855) 824-7233

MATERIAL	TITLE
	NORTH RICHLAND HILLS PD
FINISH	
PAINT	ROADSIDE
WEIGHT	
SCALE	
INCH BY	
DATE	
ISSUED BY	
DATE	
DESIGNED BY	
DATE	
DRAWING NUMBER	
REVISED BY	
DATE	

LAST SAVED: 2/28/2019

SHEET 1 OF 1