

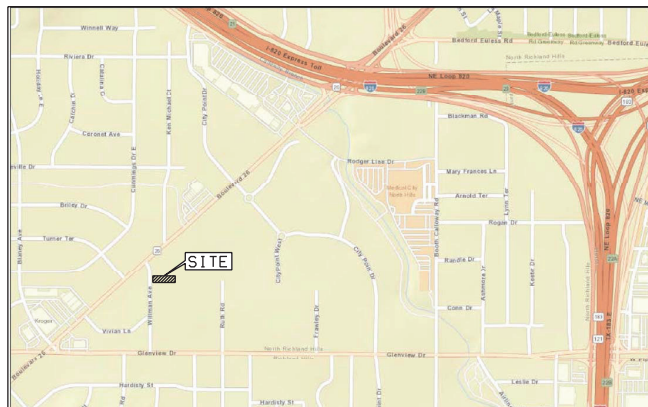

LEGEND

PROPOSED 5" THICK CONCRETE PAVING W/ #3 BARS @ 18" O.C.E.W. (3,500 PSI CONCRETE)



Vicinity Map
N.T.S.

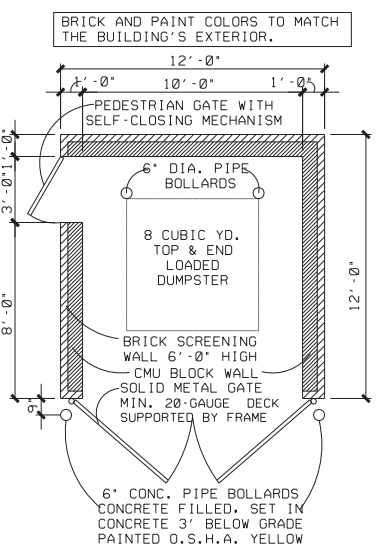
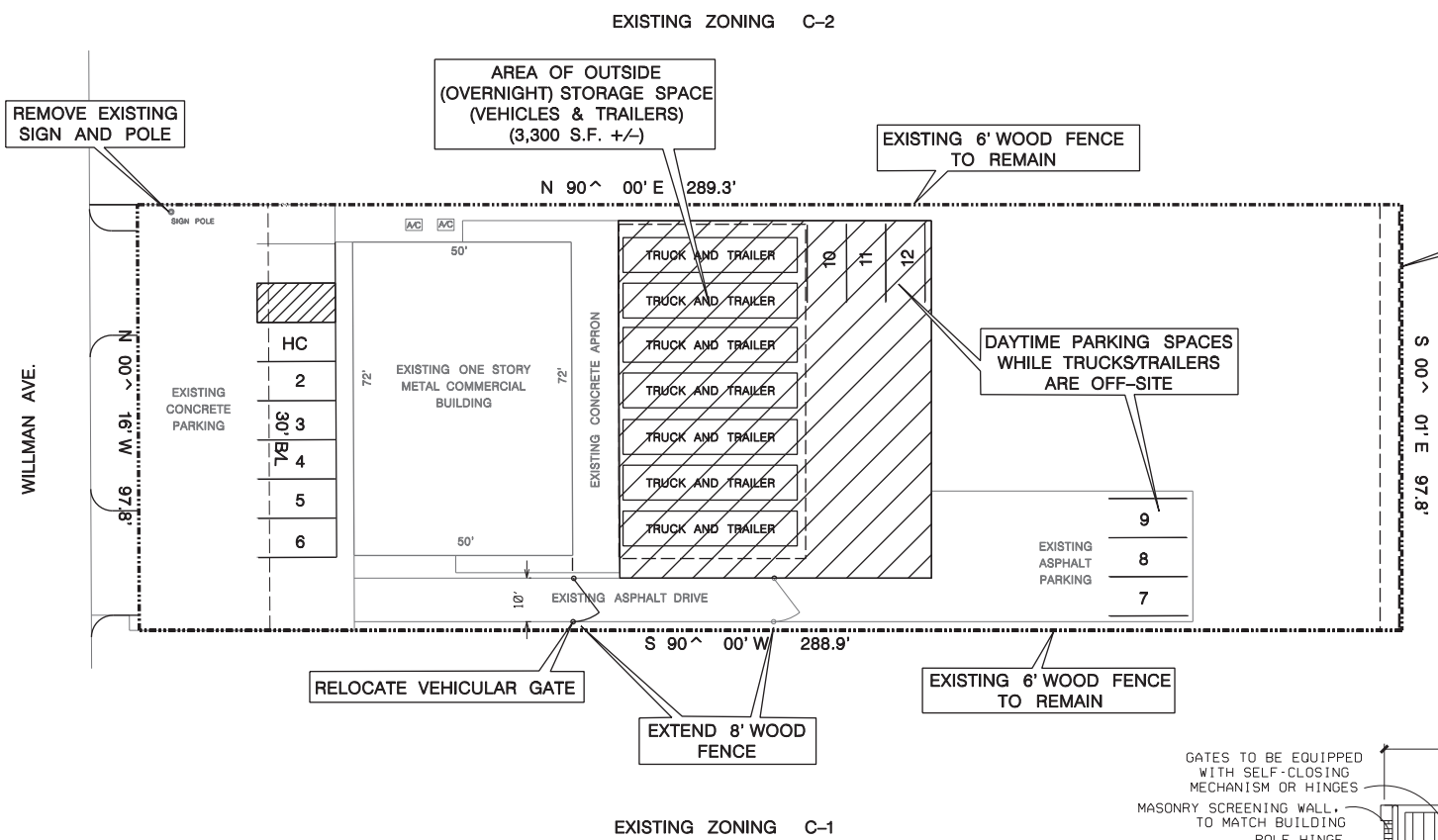

REFUSE CONTAINER
PLAN VIEW (TYP.)
N.T.S.

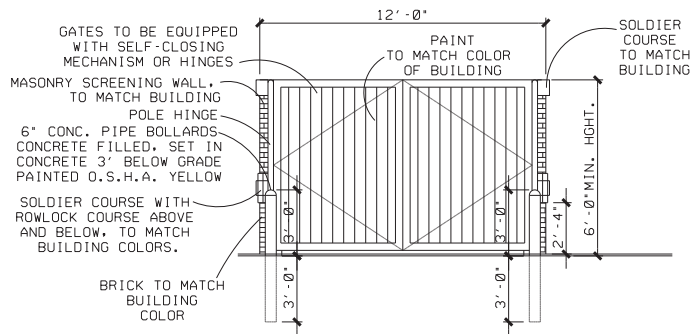

REFUSE CONTAINER
ELEVATION
N.T.S.

SITE DATA SUMMARY

EXISTING ZONING	LR
PROPOSED ZONING	C-1
LOT AREA	28,264 S.F.
BUILDING AREA	3,500 S.F.
LOT COVERAGE	12.4%
EXISTING AREA OF IMPERVIOUS COVERAGE	12,533 SF (44%)
PROPOSED NEW PAVING	5,890 S.F.
PROPOSED AREA OF IMPERVIOUS COVERAGE	18,423 SF (65%)
NUMBER OF PARKING SPACES PROVIDED	BELOW

PARKING TABULATION

OFFICE SPACE PARKING REQUIRED:
SPACE = 3,500
1 SPACE FOR EVERY
300 SF = 12 SPACES
PROVIDED: 12 SPACES

- NOTES:**
- MATERIALS OR COMMODITIES WITHIN OUTDOOR STORAGE AREA CAN NOT BE STACKED AT A HEIGHT GREATER THAN THE HEIGHT OF THE SCREEN WALL.
 - PAVED AREA IN REAR TO ACT AS PARKING FOR PERSONAL VEHICLES DURING THE DAY AND PARKING FOR WORK TRUCKS AND TRAILERS OVERNIGHT.

OWNER:
JK REALTY, LLC
8241 MID-CITIES BLVD., #100
NORTH RICHLAND HILLS, TX 76182
817-268-0408

ENGINEER:
HAMILTON DUFFY, P.C.
8241 MID-CITIES BLVD., #100
NORTH RICHLAND HILLS, TX 76182
817-268-0408
EMAIL: khamilton@hamiltonduffy.com

4170 WILLMAN AVE.
LOT 10, EDGLEY ADDITION
CITY OF NORTH RICHLAND HILLS, TEXAS

CURRENT ZONING: LR (Local Retail)
PROPOSED ZONING: C-1 Commerical District

DATE OF PREPARATION 7-24-19
REVISED 10-29-19
REVISED 11-11-19

CASE ZC 2019-13

HAMILTON DUFFY, P.C.
CONSULTING
CIVIL & ENVIRONMENTAL ENGINEERS - PLANNERS - CONSTRUCTION MANAGERS
8241 MID-CITIES BLVD., NORTH RICHLAND HILLS, TEXAS 76182
PHONE (817) 268-0408 WWW.HAMILTONDUFFY.COM

4170 WILLMAN AVE.
LOT 10, EDGLEY ADDITION
CITY OF NORTH RICHLAND HILLS, TARRANT COUNTY, TEXAS

SITE PLAN

PRELIMINARY
FOR REVIEW ONLY
THESE DOCUMENTS ARE FOR DESIGN REVIEW PURPOSES ONLY. THEY ARE NOT TO BE USED FOR BIDDING OR PERMIT PURPOSES. THEY WERE PREPARED BY, OR UNDER SUPERVISION OF:
KEITH M. HAMILTON 87184 #DATES
PE. NO. DATE

JOB	082-034
DATE	11/11/2019
DESIGNED	K.A.M.H.
DRAWN	J.B.E.
CHECKED	K.A.M.H.
TEXAS FIRM REG. NO.	P-5260

NO.	REVISION	BY	DATE

SHEET
1 OF 1